



Catch Basins

Catch Basin Type 1-L WSDOT B-5.40-02

Reinforcing

- ASTM / WSDOT requirements
- All components
- #3 grade 60 reinforcing

Riser Sections

- Available in 2", 4", 6" & 12"
- Lift holes provided in all risers and must be grouted up from both inside and outside to assure watertight structure

Reducing Top Slab

- Standard unit is designed for frame and grate to be placed on top.

Precast Base

- The unit is provided with 25 inch diameter knockouts on all four sides leaving minimum wall thickness of 2 inches
- Lift holes provided in all risers and must be grouted up from both inside and outside to assure watertight structure

Weights

- Base Unit2,480 lbs
- 6 inch Reducing Top.....430 lbs
- 12 inch Riser Section.....537 lbs
- 6 inch Riser.....280 lbs

Conformity Standards

- Washington State APWA / WSDOT Standard Specifications
- WSDOT B-1a

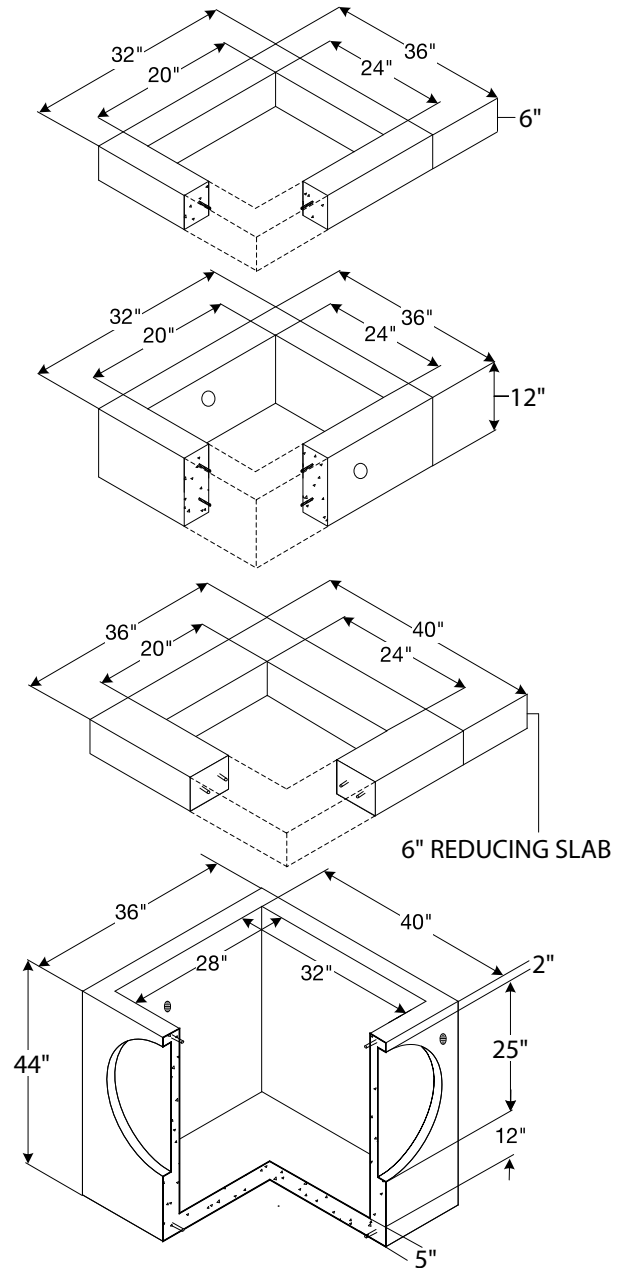

Note: Drawings not to scale

www.shopeconcrete.com

1-800-422-7560 [TOLL FREE]



Shope Concrete, LLC
1618 East Main Avenue
Puyallup, WA 98372-3142

(253) 848-1551
Fax Line 1 (253) 845-0292
Fax Line 2 (253) 864-6172

